

Simple 0 to 6 MHz DDS VFO using Analog Devices AD9832

by Johan Bodin, SM6LKM.

Please note:

This is NOT meant as a detailed building instruction for a DDS VFO. It is only a few fragments from my experimental work in the shack. This is "as is" information. It may contain errors. However, my own prototype works very well.

If you find this VFO interesting and want more information, or if you run into problems, such as missing information, errors etc, please contact me via email: sm6lkm.jbeab@swipnet.se

WHAT'S THIS?

This is a 0 - 6 MHz DDS VFO controlled by a PIC16F84 (or 'C84).

The VFO is separated into two modules, the DDS module and the controller module. The PCB layout (double sided) for the DDS module is included as two Postscript files (scale 1:1). The .PS files can be copied to a Postscript capable printer such as HP LaserJet 4MP. Please note that the layout is mirrored to get the toner side of the film toward the PCB surface.

Check the text on the layout to make sure that you don't make a mirrored PCB!

There is no PCB layout for the controller. The controller is so simple, it can be built on a piece of Veroboard.

Most of the components are surface mounted on the top side of the DDS module board. The through-hole components are mounted on the bottom side (but soldered on the top side). There are a few via holes for ground connection between top and bottom. Solder thin wires through these holes before you start to solder the components. It doesn't hurt to drill a few more via holes in addition to those shown on the layout. I made extra ground vias between L2 and L3 (at the board edge close to C10), close to the ground pin of oscillator U1 and close to the grounded end of C17.

Bend the pins of the voltage regulator, IC2, so that the TO-220 case is laying on the ground plane. The top of the cooling tab can be soldered to the ground plane for mechanical stability.

A "canned" oscillator is not the best choice for high stability but it provides an easy way to get going...

CONTROLLER PROGRAM

The PIC program is a prototype. Some of the code has been borrowed from another DDS control program (for AD9850) written by Curtis W. Preuss, WB2V. The current version has the following functions:

- Rotary encoder input for tuning
- Dial lock switch
- Step size switch (1, 10, 100, 1 kHz, 10 kHz)
- LCD interface, shows frequency (in Hz) and step size
- f/4 display possible (for I/Q front ends using LO divider)

The smallest step size is 1 Hz (although the AD9832 is able to tune in 5.8 mHz (millihertz!) steps).

The PIC interfaces to a standard 1x16 LCD which is run in 4-bit mode. Almost any LCD with Hitachi HD44780 controller will work.

Since the PIC controller is not onboard the DDS module, there is no reason why you couldn't use, for example, your PC to control the DDS through the printer port. Only three lines are needed to control the AD9832. Have a look at the AD9832 data sheet for detailed information. (Available in PDF format from <http://www.analog.com>). AD9850 and AD9851 data sheets are also worth reading for general DDS information.

CONTROLLER HARDWARE

PIC16F84 (or 'C84)			
	-----\ -----		
LCD D6, DDS SCLK -----	RA2	RA1	--- LCD D5
LCD D7, DDS SDATA -----	RA3	RA0	--- LCD D4
F/4 select -----	RA4	OSC1	--- XTAL a, 22pF to GND
4k7 pullup to +5V -----	/MCLR	OSC2	--- XTAL b, 22pF to GND
Ground -----	VSS	VDD	--- +5V
Encoder phase A -----	RB0	RB7	--- DDS FSYNC
Encoder phase B -----	RB1	RB6	--- LCD E
Step switch to GND ---	RB2	RB5	--- LCD R/W
Lock switch to GND ---	RB3	RB4	--- LCD RS

- * D0 to D3 on the LCD module are not connected.
- * RA2 and RA3 are connected to both LCD and DDS.
- * F/4 pin (RA4):
 - 0 - LCD shows actual output frequency
 - 1 - LCD shows output frequency divided by 4
- * The inputs for step pushbutton and lock switch do not need pull-up resistors (they have internal pull-up in the PIC).
- * XTAL is 4 MHz.
- * Decouple +5V to GND close to the PIC with 0.1 uF ceramic.
- * The controller can be powered from the DDS module.
- * If the encoder is running backwards, swap RB0 and RB1.
- * X2 connector on DDS module as viewed from bottom side:

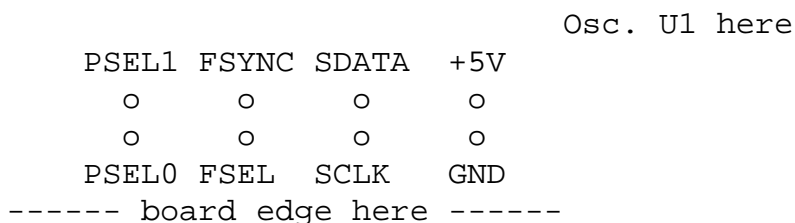

PSEL0, PSEL1 and FSEL pins are not used by this controller and should be connected to ground.

DDS MODULE COMPONENTS

C1	0.1 uF	ceramic, size 0805
C2	4.7 uF 6V	tantalum, size EIA3216
C3	0.1 uF	ceramic, size 0805
C4	0.01 uF	ceramic, size 0805
C5	0.01 uF	ceramic, size 0805
C6	0.1 uF	ceramic, size 0805
C7	4.7 uF 6V	tantalum, size EIA3216
C8	82 pF	ceramic, size 0805
C9	180 pF	ceramic, size 0805
C10	180 pF	ceramic, size 0805
C11	82 pF	ceramic, size 0805
C12	1 uF	ceramic, size 0805
C13	1 uF	ceramic, size 0805
C14	0.1 uF	ceramic, size 0805
C15	1 uF	ceramic, size 0805
C16	0.1 uF	ceramic, size 0805
C17	4.7 uF 25V	tantalum, size EIA6032
IC1	AD9832BRU	(Analog Devices)
IC2	7805	(TO-220 size)
IC3	MAX4012	(Maxim)
L1	10 uH	Coilcraft 1812CS
L2	12 uH	Coilcraft 1812CS
L3	10 uH	Coilcraft 1812CS
L4	10 uH	Coilcraft 1812CS
R1	3.9 k	size 0805
R2	300 ohms	size 0805
R3	330 ohms	size 0805
R4	11 k	size 0805
R5	1.5 k	size 0805
R6	3.3 k	size 0805
R7	470 ohms	size 0805
R8	150 ohms	size 0805
R9	47 ohms	size 0805
R10	10 k	size 0805
U1	25 MHz	(for example IQD IQXO-22)
V1	1N4007	
X1	2x1 pin strip, 0.1" spacing	
X2	2x4 pin strip, 0.1" spacing	
X3	2x1 pin strip, 0.1" spacing	
Z1	Murata DSS306-55FFZ103N100, 0.01 uF	

File list

ad9832_4.asm	PIC assembly source code
p16f84.inc	Needed for assembly of ad9832_4.asm (for 'F84)
p16c84.inc	As above but for 'C84
vfo5x7f.hex	PIC16F84 program for LCD with 5x7 font
vfo5x10f.hex	PIC16F84 program for LCD with 5x10 font
vfo5x7c.hex	PIC16C84 program for LCD with 5x7 font
vfo5x10c.hex	PIC16C84 program for LCD with 5x10 font
filtresp.pcx	Computed frequency response of lowpass filter

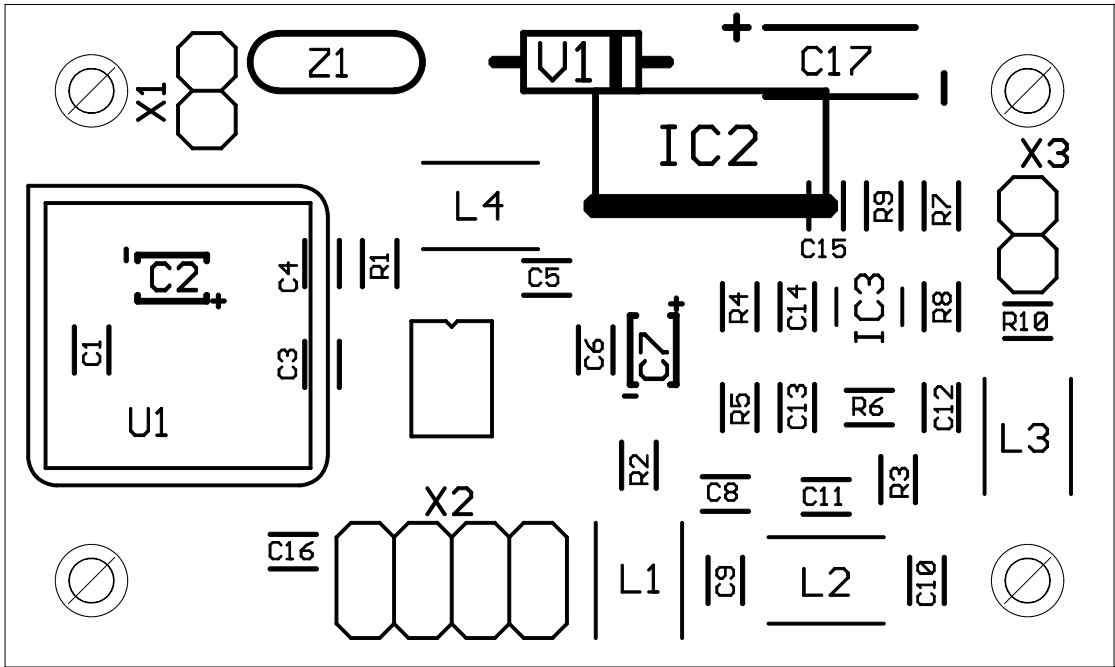

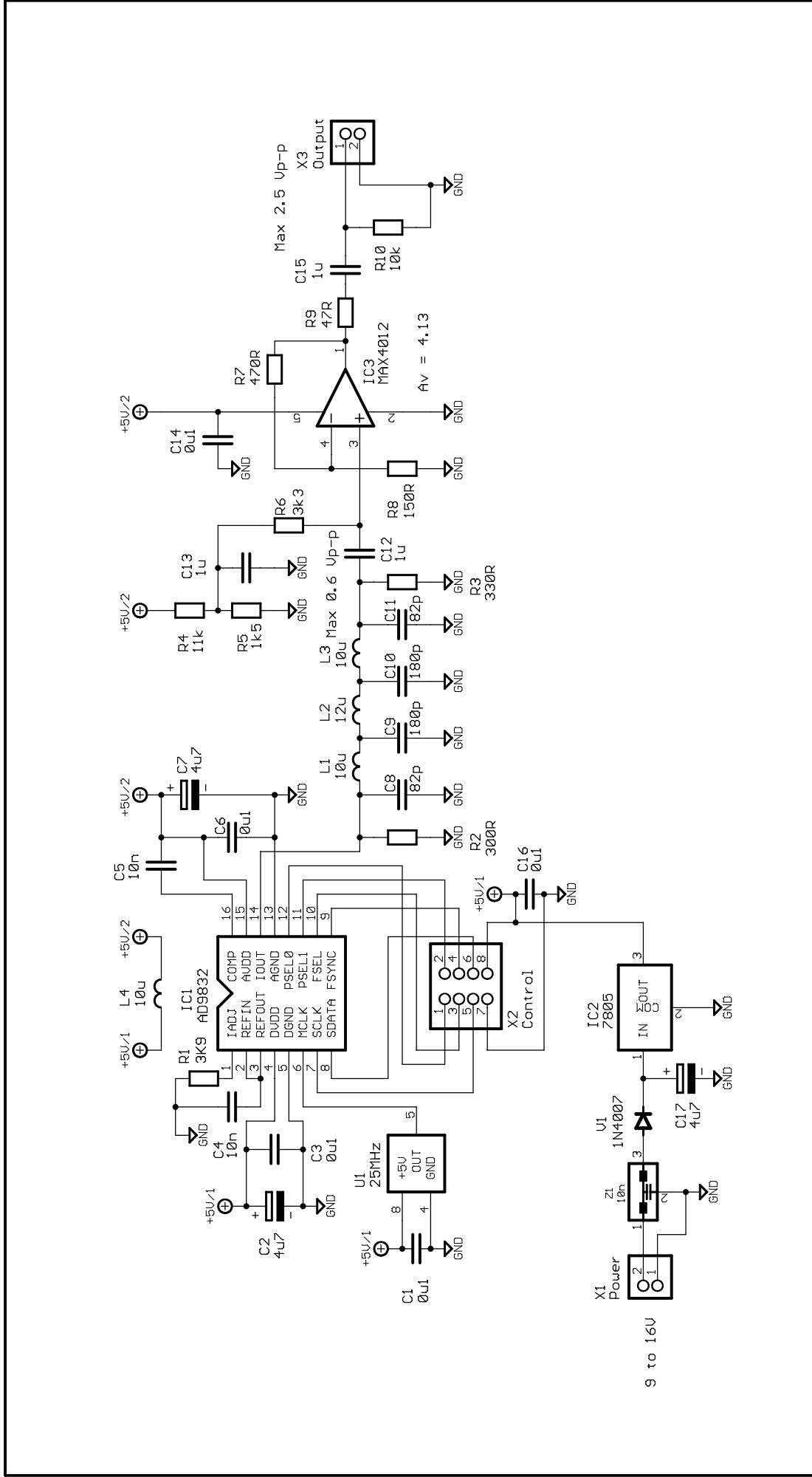

SM6LKM Mini DDS VFO

TITLE: nco

Document Number:

REV:

Date: 1999-02-17 22:07:02

Sheet: 1/1

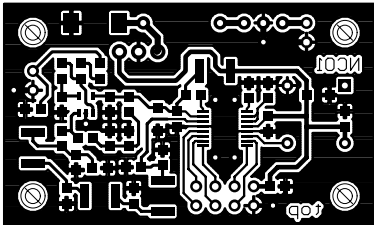

motorpod



100M



Lowpass filter for mini DDS

